

MANON - 1419

COMPACT - 1200 W MSD



- **Type:** Followspot
- **Source:** 1200 W MSD
- **PSU:** Magnetic
- **Optics:** 13° to 24° zoom

Followspot

Economical yet full of features

The full range of features on Manon brings Robert Juliat quality within reach of all budgets. Long lamp life and low running costs provide a powerful, cost-effective solution for mid-size theatres, shows and rental companies alike.

Features

- **Fully closing iris cassette:** removable for fast, easy replacement; protective backplate for extended lifespan
- **Universal adjustable gobo holder:** "A" size glass and metal gobos
- **Ergonomic dimmer control:** one-handed dim, pan and tilt. Dimmer control can be adjusted to suit the operator's preference
- **Smooth dimmer shutter:** retains flat beam and colour temperature when dimming
- **Frost filter:** on flip lever for quick soft-edge beam effect
- **Horizontal chopper (optional):** for masking control in TV studios and wide stages
- **Internal glass filter holder:** long term use of durable coloured, dichroic or textured glass
- **Individually removable colour frame:** gels replaced easily while colour cassette remains in place
- **Colour changer:** 6-way, 'push/pull' colour changer system for simultaneous use of multiple filters
- **Easy focus reference:** graduated scale on side of the unit; fast and easy refocusing
- **Adjustable yoke (optional):** for optimum overhead positioning
- **Fine balance:** precision positioning and smooth operation even with the smallest movements
- **Stand:** perfectly weighted for maximum stability with smooth rotation for optimum performance. Easy set up; triple safety system for extra security

Optical

- **Long lamp life (3000 h)**
- **Factory set optical train:** travels safely within followspot and requires no time-consuming realignment on arrival. Uniform beam on all followspots of same type
- **SX optical system:** double condenser optics for exceptional optical quality
- **Gobo :** excellent gobo projection
- **Variable zoom optics:** sharp focus at every beam angle. Independent control of image size and focus.

Construction

- **Made in France :** fully manufactured in Robert Juliat premises retaining complete control over all aspects of quality
- **Separate PSU:** compact for easy handling and rapid maintenance
- **G22 socket locking system exclusive to Robert Juliat:** holds the lamp securely in place to ensure there is no arcing, even when the fixture is pointing vertically downward
- **Bodywork:** strong sheet metal construction for durability
- **Ergonomic wrap-around handle:** comfort, safety and practicality from all operating positions
- **Moving parts:** smooth at all times, even when hot
- **Captive knobs and handles:** additional security when working at height or in transit
- **Easy access to all parts:** easy cleaning, re-lamping and maintenance
- **Removable assemblies:** fast-plug cable connectors and complete component assemblies (mirror, condenser set and lamp house assembly) save maintenance and cleaning time

Picture:1419 + FRO/1117PV

DSEN112_1419 - 08/11/2024

Robert Juliat reserves the right to change or alter any of the items detailed on this page, to increase or improve manufacturing techniques without prior notice.

Robert Juliat S.A.S., 32 rue de Beaumont, 60530 Fresnoy-en-Thelle - France
Telephone : +33 (0)3 44 26 51 89 - info@robertjuliat.fr - www.robertjuliat.com



ROBERT JULIAT

Source



- **Lamp type:** Discharge
- **Power:** 1200 W
- **Socket:** G22
- **Hot re-strike:** no

| Admissible lamps | Power * | Lumen output* | Colour temperature* | Life* | CRI* (min) |
|---------------------|---------|---------------|---------------------|---------|------------|
| MSD 1200W (Philips) | 1 200 W | 92 000 lm | 6000K | 3 000 h | 80 |

(*) manufacturer's data

Optics

Characteristics

- **Type:** Zoom
- **Range:** 13° to 24° (Field angle)
- **Focal length:** 169 - 316 mm

Gel filter

- **Shape:** Circle
- **Standard size:** 210 mm (8.3 in)

Gobo

- **Size:** A
- **Material:** Metal
Glass



Photometrics

optics: 13°-24° / Standard / MSD 1200W (Philips)

• Optics @ 13°

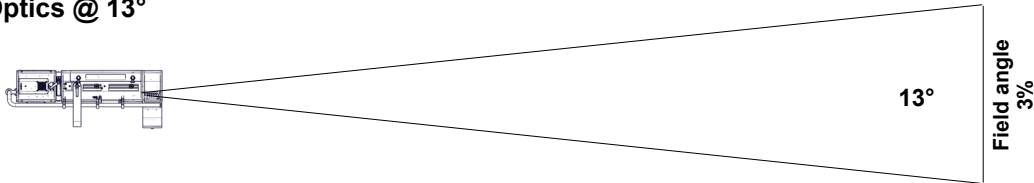

Beam intensity
650 000 cd

| | | | | | | |
|---------------------|------------|-----------|-----------|-----------|-----------|---------|
| Distance | 5 m | 10 m | 15 m | 20 m | 25 m | 30 m |
| Diameter | 1.1 m | 2.3 m | 3.4 m | 4.6 m | 5.7 m | 6.8 m |
| Illumination | 26 500 lux | 6 600 lux | 2 900 lux | 1 650 lux | 1 050 lux | 730 lux |
| Distance | 15 ft | 35 ft | 50 ft | 65 ft | 80 ft | 100 ft |
| Diameter | 3.4 ft | 8 ft | 11.4 ft | 14.8 ft | 18.2 ft | 22.8 ft |
| Illumination | 2 900 fc | 540 fc | 270 fc | 160 fc | 110 fc | 70 fc |

• Optics @ 24°

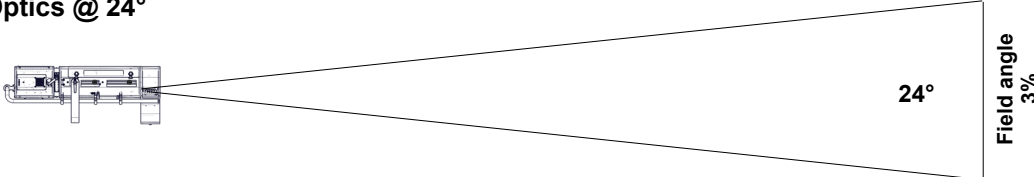

Beam intensity
230 000 cd

| | | | | | | |
|---------------------|-----------|-----------|-----------|---------|---------|---------|
| Distance | 5 m | 10 m | 15 m | 20 m | 25 m | 30 m |
| Diameter | 2.1 m | 4.3 m | 6.4 m | 8.5 m | 10.6 m | 12.8 m |
| Illumination | 9 300 lux | 2 350 lux | 1 050 lux | 580 lux | 370 lux | 260 lux |
| Distance | 15 ft | 35 ft | 50 ft | 65 ft | 80 ft | 100 ft |
| Diameter | 6.4 ft | 14.9 ft | 21.3 ft | 27.6 ft | 34 ft | 42.5 ft |
| Illumination | 1 050 fc | 190 fc | 95 fc | 55 fc | 36 fc | 24 fc |

Dimensions and weight

Unit

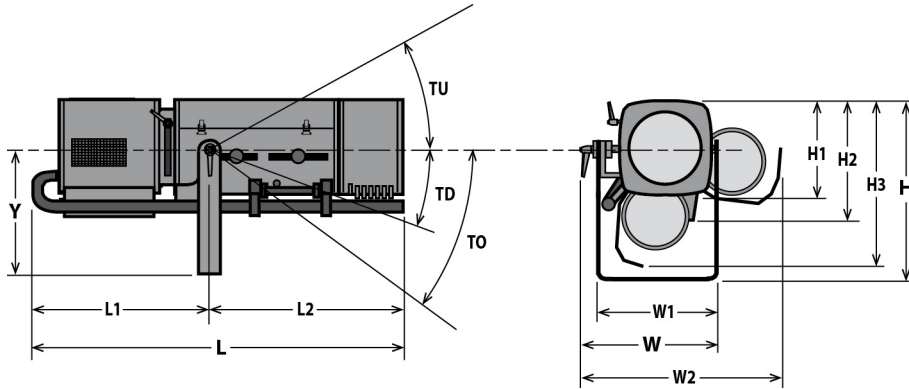

Weight: 30.2 kg (66.4 lbs)

| Height | Length | Width | Yoke | Tilt | Option |
|----------------------|----------------------|----------------------|---------------------|---------|---------|
| H= 450 mm (17.7 in) | L= 900 mm (35.4 in) | W= 410 mm (16.1 in) | Y= 325 mm (12.8 in) | TU= 40° | TO= 70° |
| H1= 250 mm (9.8 in) | L1= 425 mm (16.7 in) | W1= 350 mm (13.8 in) | | TD= 50° | |
| H2= 345 mm (13.6 in) | L2= 475 mm (18.7 in) | W2= 570 mm (22.4 in) | | | |
| H3= 460 mm (18.1 in) | | | | | |

Shipping

- **Weight :** Unit: 35 kg (52.8 lbs)
PSU: 24 kg (52.8 lbs)
- **Volume :** Unit: .2 m³ (7.06 ft³)
PSU: .04 m³ (1.41 ft³)

PSU

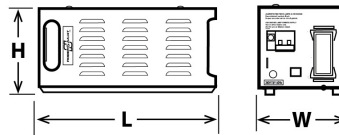

- Width:** W= 185 mm (7.3 in)
- Height:** H= 200 mm (7.9 in)
- Length:** L= 450 mm (17.7 in)
- Weight:** 23 Kg (50.6 lbs)

Installation

- **Minimum distance to illuminated surface:** 2.8 m (9.2 ft)
- **Operating position:**

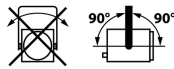

Warranty

- **Fixture: 2 years**
See General Sales Condition on website

Approvals



Construction

- **Housing:** Steel sheet - Aluminium
- **Colour:** Black
- **Cooling:** Low noise fan
- **Maximum ambient temperature (Ta):** 40°C (104°F)
- **Maximum case temperature (Tc):** 230°C (446°F)
- **Total heat dissipation:** 5 290 BTU/h
- **Ingress Protection (IP) rating:** IP20

- **PSU housing:** Steel sheet - Aluminium
- **PSU colour:** Black
- **PSU cooling:** Convection cooling
- **PSU maximum ambient temperature (Ta):** 40°C (104°F)
- **PSU maximum case temperature (Tc):** 60°C (140°F)

Electrical compatibility

- 220/230 V - 50 Hz
- 245 V - 50 Hz
- ~~110/120 V - 60 Hz~~
- 208 V - 60 Hz
- ~~220/230 V - 60 Hz~~
- ~~100 V - 50 Hz~~
- ~~100 V - 60 Hz~~
- Selector: local switch

Power input



- **Type:** attached power cord
- **Cable:** H07RNF 3G1.5
- **Length:** 3 m (9.8 ft)
- **Power connector:** CEE 7/7 (2P+E NF/Schuko)

Power consumption

| Voltage | Frequency | Current | Power | Power factor |
|---------|-----------|---------|--------|--------------|
| 230 V | 50 Hz | | 1550 W | |
| 208 V | 60 Hz | | 1550 W | |
| 245 V | 50 Hz | | 1550 W | |

Power Supply Unit

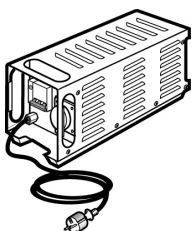







- **PSU:** Separate - Magnetic PSU
- **Lighting unit / PSU cable:** Cable attached to unit - length: 3 m (9,8 ft)
Type: 3G4 EWKF with 16A black 3P+E 7h IEC60309 connector
- **Maximum distance between lighting unit and PSU:** 25 m (82 ft)
- **Control:** Local
- **Protection:** Mains: 16A 2P2D - C curve breaker / Electronic: 10A 2P2D - C curve breaker









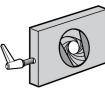

Model





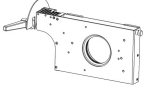









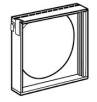

| | |
|-------------|--|
| 1419 | 1200 W MSD Followspot - 1419 Manon - 13/24° - Magnetic PSU |
|-------------|--|

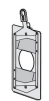
Options

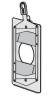
| | | |
|-------------------|---|---|
| PCP1716A | 16A blue 2P+E 6h IEC60309 power connector |  |
| FRO/1117PV | Heavy duty adjustable yoke |  |
| FRO/SMEPV | Heavy duty adjustable yoke equipped with TILT SpotMe sensor (E type) |  |
| PG80 | Ø80mm chopper kit (G80+ GR120+ adaptation kit) |  |
| M210BM | 6 ways "boomerang" colour changer |  |
| FC1459 | Flight-case for Compact range / GT stand / P.S.U. / accessories - Dim: 1340x710x700mm - Weight: 55 Kg |  |

Accessories

| | | |
|------------------|---|---|
| CCU1 | Full closing iris cassette - Ø72mm - Weight: 1.33 Kg 1 included |  |
| PF1011 | Ø210 mm metal filter holder 6 included |  |
| SGUP2 | Universal "A" size gobo-holder (metal, glass, frosted glass) 1 included |  |
| VDM100 | Ø97mm frosted glass with holder 1 included |  |
| M210T | 6 ways "push/pull" colour changer - Weight: 3.67 Kg 1 included |  |
| MSD 1200W | MSD 1200W - Philips G22 1200W 3000h 6000K lamp |  |
| CCU1SM | Full closing iris cassette with position sensor for SpotMe system - Ø72mm |  |
| GT1000 | Tripod stand - SWL: 40 Kg - max. height: 1550 mm - Weight: 9.27 Kg |  |
| GT4000 | Tripod stand with safety chain - SWL: 130 Kg - max. height: 1030 mm - Weight: 7.91 Kg |  |
| GT4000RSM | Tripod stand with ball head rotation with security chain and SpotMe PAN sensor - SWL: 130 Kg - max. height: 1030 mm |  |

| | | |
|-------------------|---|---|
| GT4000S | Tripod stand without safety chain - SWL: 130 Kg - max. height: 1030 mm - Weight: 8.65 Kg |  |
| JPP | Monopod stand for overhead followspot - Weight: 3.6 Kg |  |
| T1000 | TV spigot with followspots swivel head - Weight: 1.82 Kg |  |
| T4000 | Followspot mount for Ø50mm pipe (suspension or overhead) - SWL= 100 Kg - Weight: 4.88 Kg |  |
| T4000RSM | Followspot mount with ball head rotation and SpotMe PAN sensor - SWL = 100 Kg - Weight: 8.53 Kg |  |
| CAV700A | Double slot front cassette for 215x215mm accessories - Weight: 0.52 Kg |  |
| FCM100R | Ø97mm 1/2 CTO correction filter (Rosco #3408) with holder |  |
| VD120 | 120x120mm frosted glass |  |
| FRO/1017PD | Heavy duty adjustable yoke - Weight: 4.33 Kg |  |
| FRO/SMEPD | Heavy duty adjustable yoke equipped with TILT SpotMe sensor (E type) |  |
| G80 | Ø80mm horizontal chopper - Weight: 0.37 Kg |  |
| GR120 | Slot reducer for SGUP gobo holder (if PG80 option) - Weight: 0.2 Kg |  |
| Kit G80 | Ø80mm chopper kit (G80+ GR120+ adaptation kit) - Weight: 0.69 Kg |  |
| M210B | 6 ways "boomerang" colour changer - Weight: 3.36 Kg |  |
| M210TVCL | Light shield for M210T push/pull colour changer - Weight: 1.98 Kg |  |
| BK/E1 | Extra weight kit for BK1 (0,5 Kg) - Weight: 0.5 Kg | |
| BK1 | Followspot balancing kit (including 1 Kg counterweights) - Weight: 2.05 Kg |  |
| Kit TELRAD | Telrad followspot sight with raiser and universal mounting kit - Weight: 1.23 Kg |  |
| SDUP | Followspot cue sheet holder with universal mounting kit |  |

TCSM

SpotMe calibration tool kit



Maestro

Maestro server for SpotMe - rackable unit: 1U - half 19" - Weight:
1.2 Kg

